

LED Alarm Light



Part No. LX-60P



The Ingram LX60P Versi-lux is a super bright LED panel mount light that is daylight visible. It requires a 2" knockout to mount, and can be installed on panels up to 1/4" thick. Meets UL Type 3, 3R, 4, 4X, 12 and 13.

VISIBLE IN DIRECT SUNLIGHT

Features

- Standard comes w/ choice of 1 color
- Optionally, can have two colors
Top/Bottom or alternate sides
- Adjustable flash length, from 10 per second to 1 every 100 hrs, when flashed w/ Ingram PN H3D-M
- Super Bright energy efficient LED's
- Available in your choice of 5 colors (White, Blue, Green, Amber, & Red). Light can be used with 1 or 2 colors
- Lens Molded from 2.5 mm thick Lexan
- Provides 360° visibility
- Comes with gasket and mounting hardware
- Each Color may be flashed independently either horizontally or vertically



Technical Specifications (Per LED Module)

- Voltage: 12VDC
- Current Draw: 60 mA
- View angle: 150 degrees
- Life: 50,000 hrs
- Total Unit Wattage: 12.0

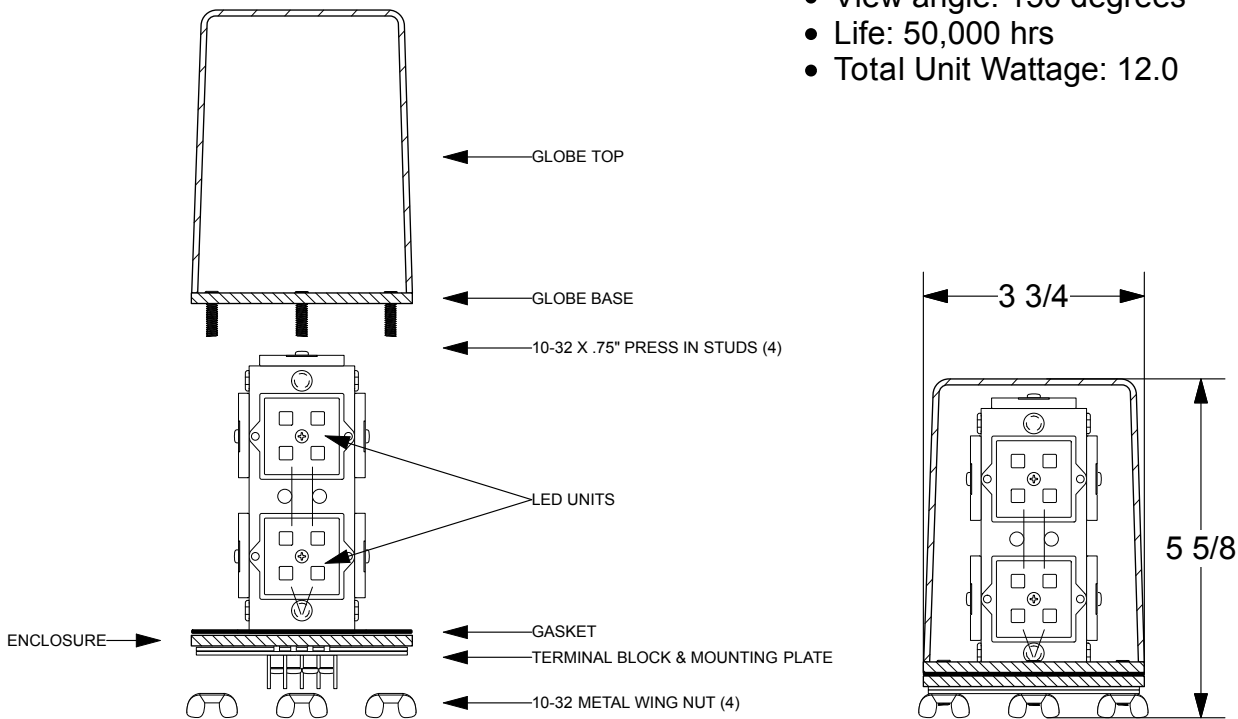

ALWAYS REMOVE POWER BEFORE SERVICING ANY BULB

Alarm Light

Part No. LX-60P

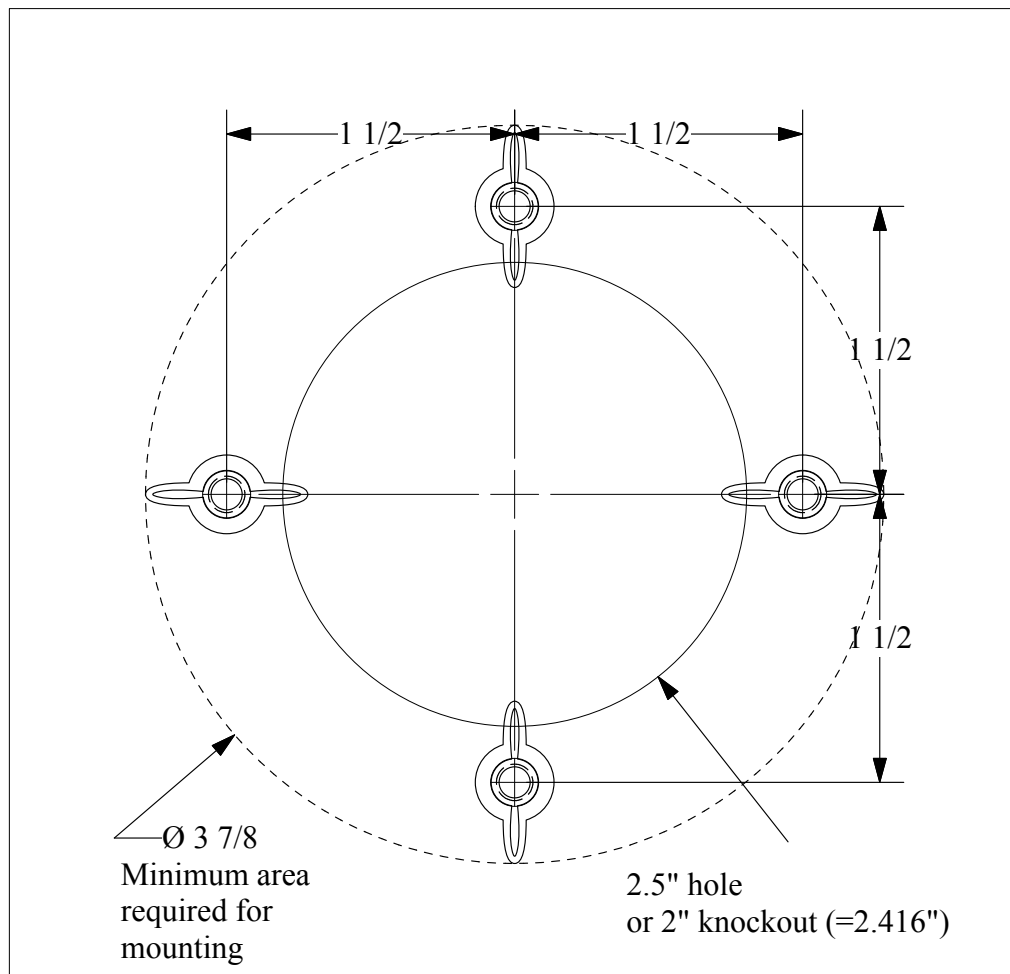

Mounting Template
Scale 1:1

Assembly Instructions

