

Alarm Light

Part No.: MX15



The Ingram MX15 is a UL Type 3, 3R, 4, 4X, 12, 13 low cost alarm light suitable for heavy duty applications inside and outdoors. The lens is molded from tough shatter resistant GE Lexan. This light is particularly useful in areas with high ambient noise levels where an audible signal may not be heard.

Features

- UL Recognized for use with UL NEMA Type 3, 3R, 4, 4X, 12 and 13 enclosures (E121431)
- Lens molded from GE Lexan that is shatter resistant and UV stabilized
- Top mounted gives 360 degree visibility
- Easy to install - One hole to punch
- Hose down proof
- Available in red or amber

Technical Specifications

- Voltage: 12V, 24V AC/DC, 120VAC
- Current Draw: 120VAC 0.125 amps
12V AC/DC 1.25 amps
24V AC/DC 0.625 amps

12 and 24V, 15W bulbs are available for special order.
Supplied with 15 watt, 120V bulb.

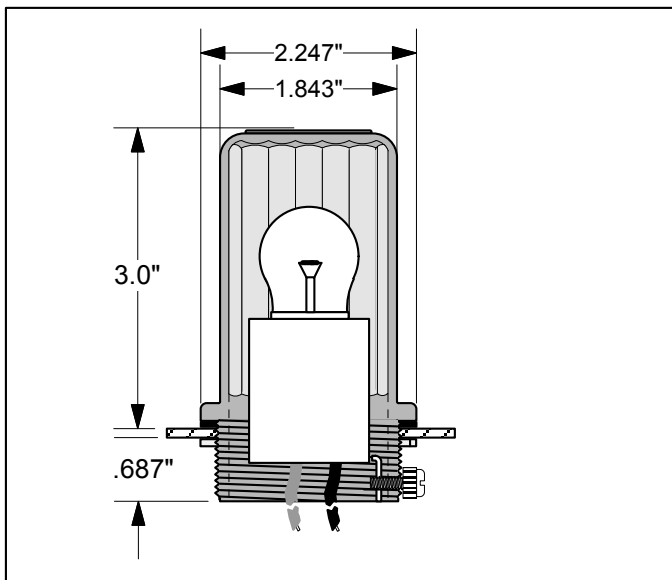

Cut-Away View

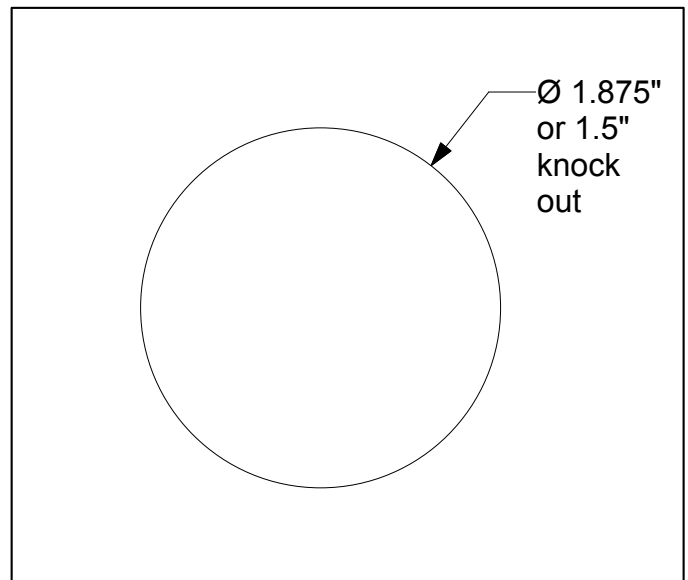

Hole Pattern For Mounting

Rev. 3

Shatter Resistant
G.E. Lexan Globe

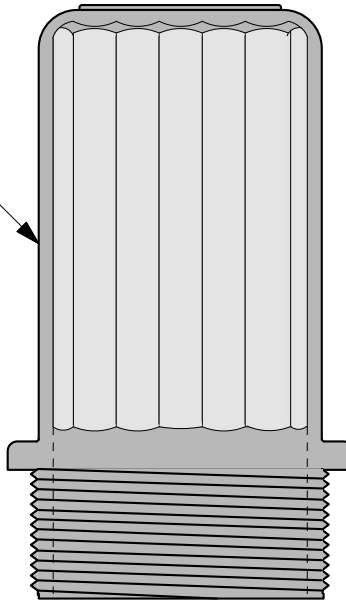

Gasket

Nylon Thumb
Screw

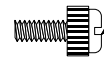

Enclosure Wall

.250" Max

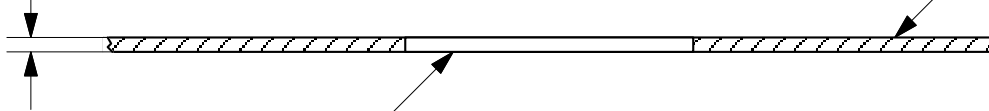

1.5" knock out
or 1.875 Hole

Socket with 36"
Wire leads

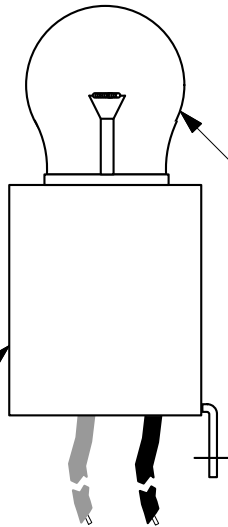

15 Watt Bulb



Locknut

MX15 Assembly