

LED Alarm Light



Model: LX60LED



The Ingram LX60LED is designed for UL type 3, 3R, 4, 4X, 12, and 13 environments. The bulb is equivalent to a 60 watt incandescent bulb, but since it employs LED technology it only consumes 13 watts of power. The alarm light is suitable for heavy duty applications indoors and outdoors. The lens is molded from shatter resistant GE Lexan. This tamper resistant light is particularly useful in areas with high ambient noise levels where an audible signal may not be heard.

Features

- UL recognized for use with UL Type 3, 3R, 4, 4X, 12, and 13 enclosures (E121431)
- Lens molded from GE Lexan that is shatter resistant and UV stabilized
- Weather/Hose Down Proof, and corrosion resistant
- Available in Red, Clear, and Amber
- High Intensity, visible in direct sunlight
- As bright as a 60 watt light - but only uses 13 watts.
- No tools needed for installation- just tighten the included wingnuts

Technical Specifications

- Voltage: 120VAC
- Current Draw: 75mA
- Life Expectancy: 25,000 hrs. minimum
- Brightness: 850 lumens
- Lens Material: Lexan
- Power Consumption: 13 watts
- Dimensions: 3.5" O.D x 4.5" H
Weight: 1.1 lbs.

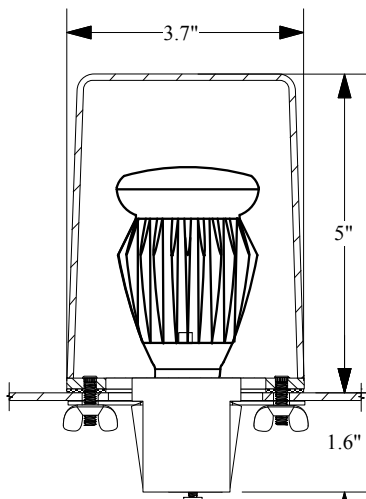

Cut Away View

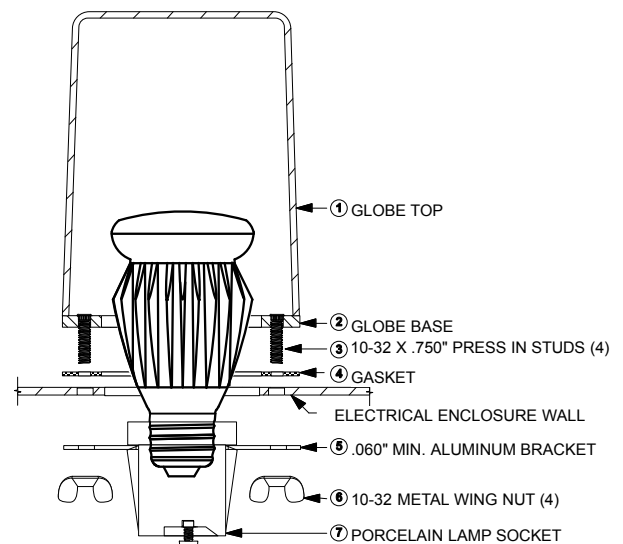

LX60LED Assembly

REV. 0

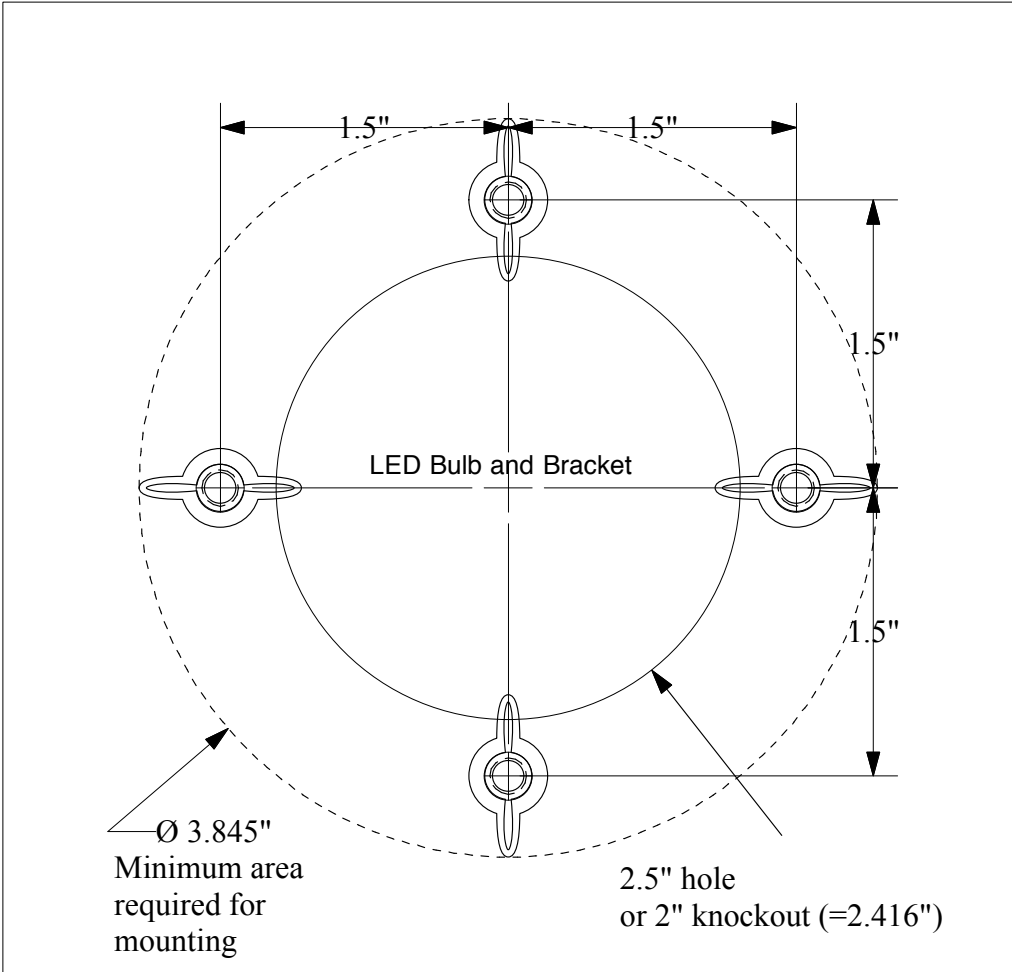

Mounting Template