

Alarm Light

Part No.: LX25



The Ingram LX25 is a UL 3, 3R, 4, 4X, 12, 13 low cost alarm light suitable for heavy duty applications inside and outdoors. The lens is molded from tough shatter resistant GE Lexan. This tamper resistant light is particularly useful in areas with high ambient noise levels where an audible signal may not be heard.

Features

- UL Recognized for use with UL NEMA Type 3, 3R, 4, 4X, 12 and 13 enclosures (E121431)
- Lens molded from GE Lexan that is shatter resistant and UV stabilized
- Low profile, top mounted gives 360 degree visibility
- Hose down proof
- Available in 5 colors: Red, Blue, Green, Amber and Clear

Technical Specifications

- Voltage: 12V, 24V AC/DC, 120VAC
- Current Draw: 120VAC 0.21 Amps max.
12V AC/DC 2.1 Amps max.
24V AC/DC 1.1 Amps max.

12 and 24 Volt 25 watt bulbs are available for special order. Supplied with 25 watt, 120V bulb.

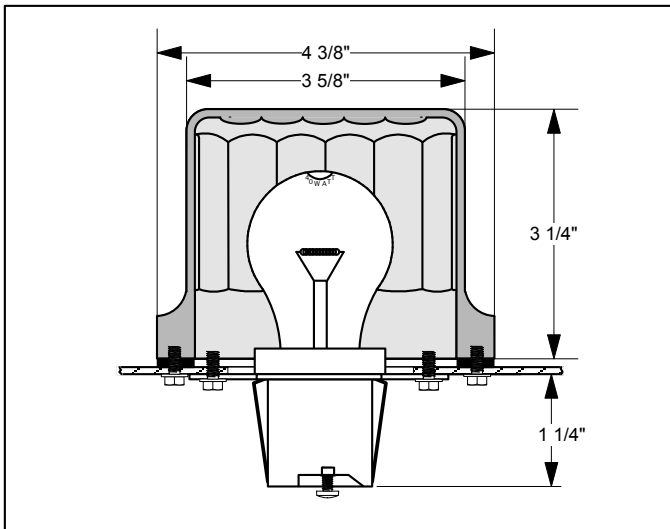

Cut-Away View

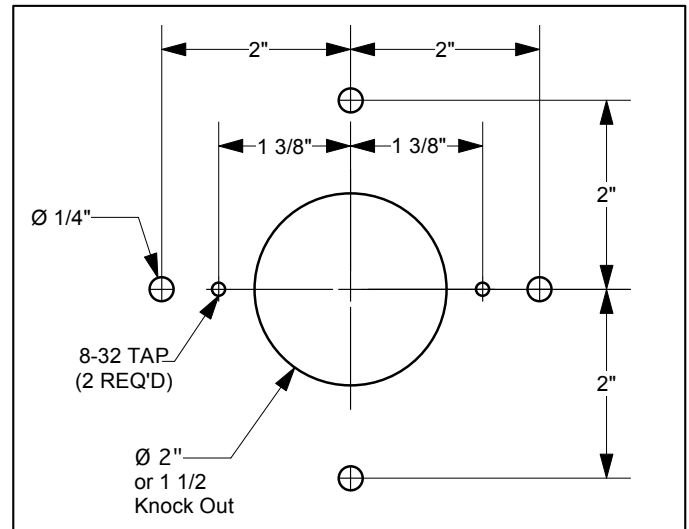

Hole Pattern For Mounting

