

TUF Pump Mounting Bracket



Part No. PV20P18M120AMTBRK



The TUF Pump Mounting Bracket makes it possible to affix the TUF Pump to a panel using a minimum amount of panel space. This sturdy bracket is constructed of corrosion resistant aluminum and comes with the necessary hardware to attach the TUF Pump.

Features / Technical Specifications

- Dimensions: 3-3/8"H x 4"W x 4-1/2"D
- Fabricated from 3003-H14 aluminum
- Finish: Brushed with gold irridite
- Metal thickness: .062
- Hardware included

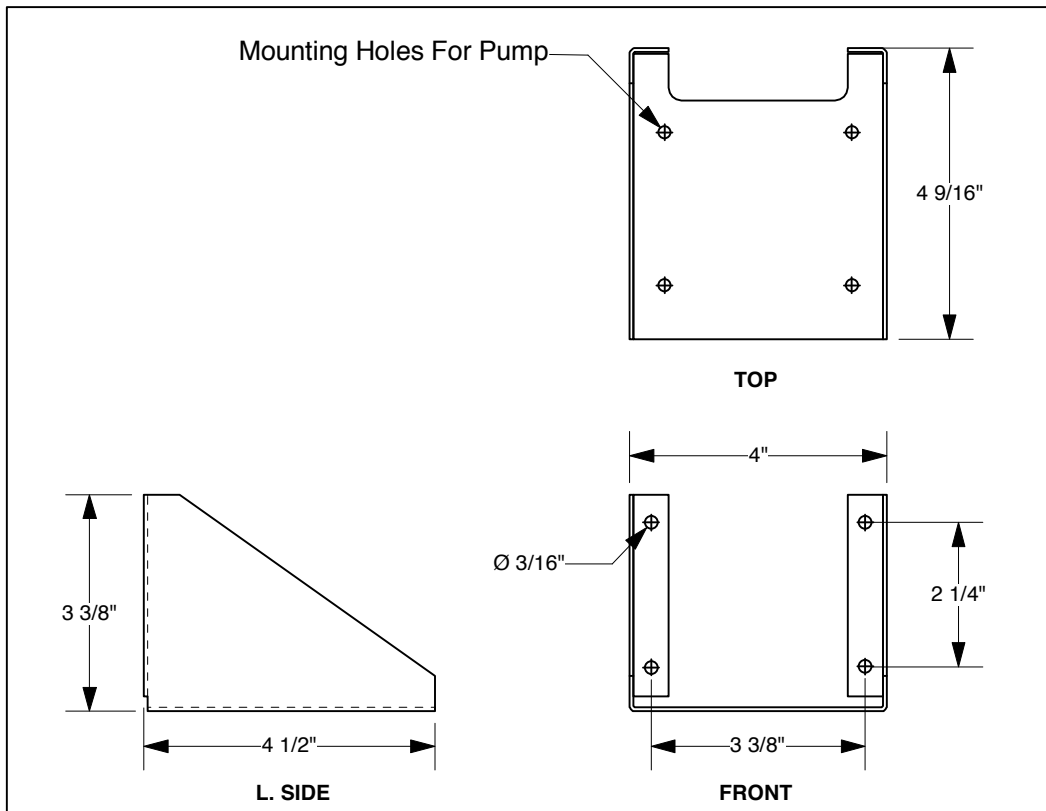

Mounting bracket hardware used to mount the TUF Pump

