

Alarm Light

Part No.: LX25



The Ingram LX25 is a UL 3, 3R, 4, 4X, 12, 13 low cost alarm light suitable for heavy duty applications inside and outdoors. The lens is molded from tough shatter resistant GE Lexan. This tamper resistant light is particularly useful in areas with high ambient noise levels where an audible signal may not be heard.

Ingram also offers daylight visible 120VAC sixty LED bulbs that fit the LX25 or any standard E26 screw-in socket.

Red LED Bulb: Ingram p/n LEDBR120A

Amber LED Bulb: Ingram p/n LEDBA120A

For best results, use red lens with red bulb, amber lens with amber bulb, or clear lens with either.

Features

- UL Recognized. Can be used in UL NEMA Type 3, 3R, 4, 4X, 12 and 13 enclosures (E121431)
- Lens molded from GE Lexan that is shatter resistant and UV stabilized
- Low profile, top mounted gives 360 degree visibility
- Hose down proof
- Available in 5 colors: Red, Blue, Green, Amber and Clear

Technical Specifications

- Voltage: 12V, 24V, 120VAC
- Current Draw:

120VAC	0.21 Amps max. (Filament)
120VAC	0.017 Amps max. (LED)
12V	2.10 Amps max. (Filament)
24V	1.1 Amps max. (Filament)

The LX25 comes with a 25 watt, 120V incandescent bulb. 25 watt incandescent bulbs at 12 and 24V are available for special order as well. They work equally well with AC or DC voltages.

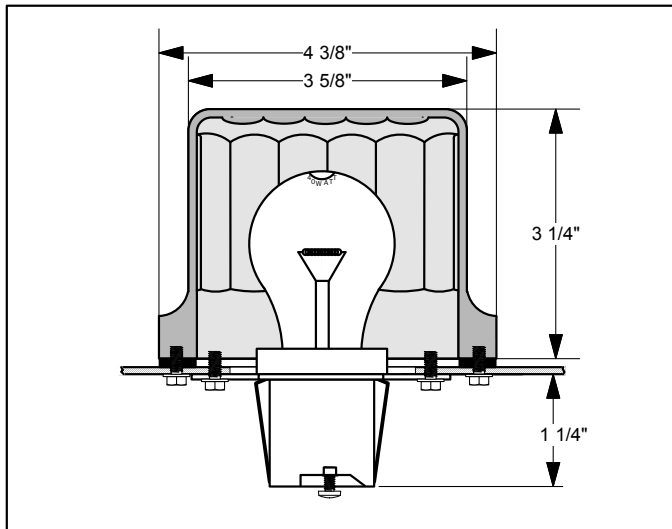

Cut-Away View

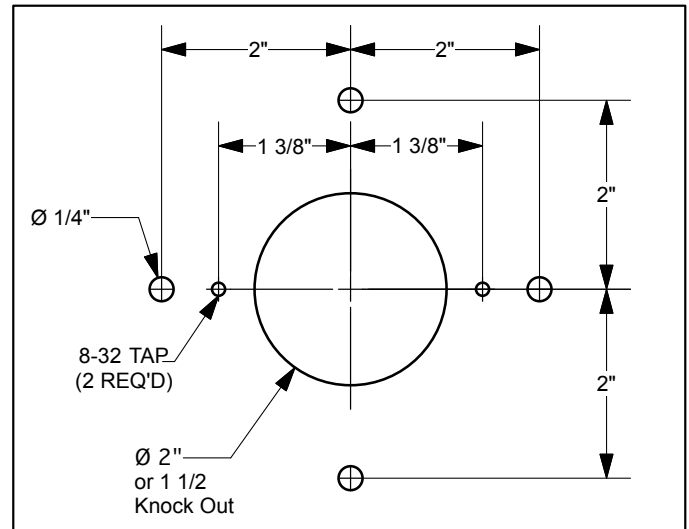

Hole Pattern For Mounting

Rev. 4

