

Flashing Alarm Light



Model: LX-100FS



The Ingram LX100FS is suitable for UL type 3, 3R, 4, 4X, 12, and 13 environments. The LX100FS flashing alarm light is suitable for heavy duty applications inside and outdoors. The lens is molded from shatter resistant GE Lexan. This tamper resistant light is particularly useful in areas with high ambient noise levels where an audible signal may not be heard.

Features

- UL recognized for use with UL Type 3, 3R, 4, 4X, 12, and 13 enclosures (E121431)
- Lens molded from GE Lexan that is shatter resistant and UV stabilized
- Weather/Hose Down Proof, and corrosion resistant
- Available in Red, Clear, and Amber
- High Intensity, visible in direct sunlight
- 100 Watt High Intensity Light
- No tools needed for installation- just tighten the included wingnuts

Technical Specifications

- Voltage: 130VAC
- Current Draw: 0.77 amps max
- Supplied with 100 watt bulb
- Heavy-duty Nickel plated light bulb socket 100-watt rough service clear appliance light bulb to withstand temperature changes
- Supplied with Ingram's SSF150 solid state flasher

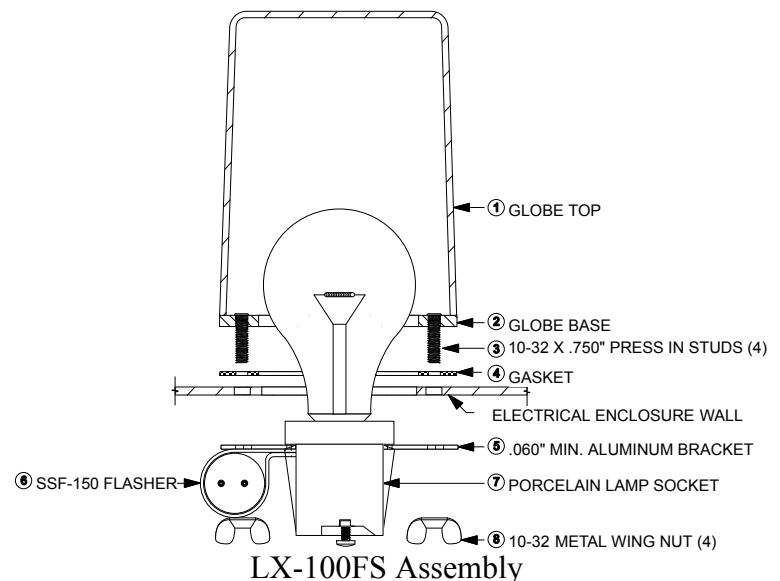
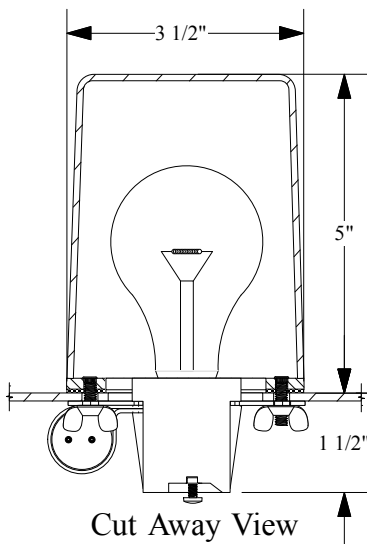

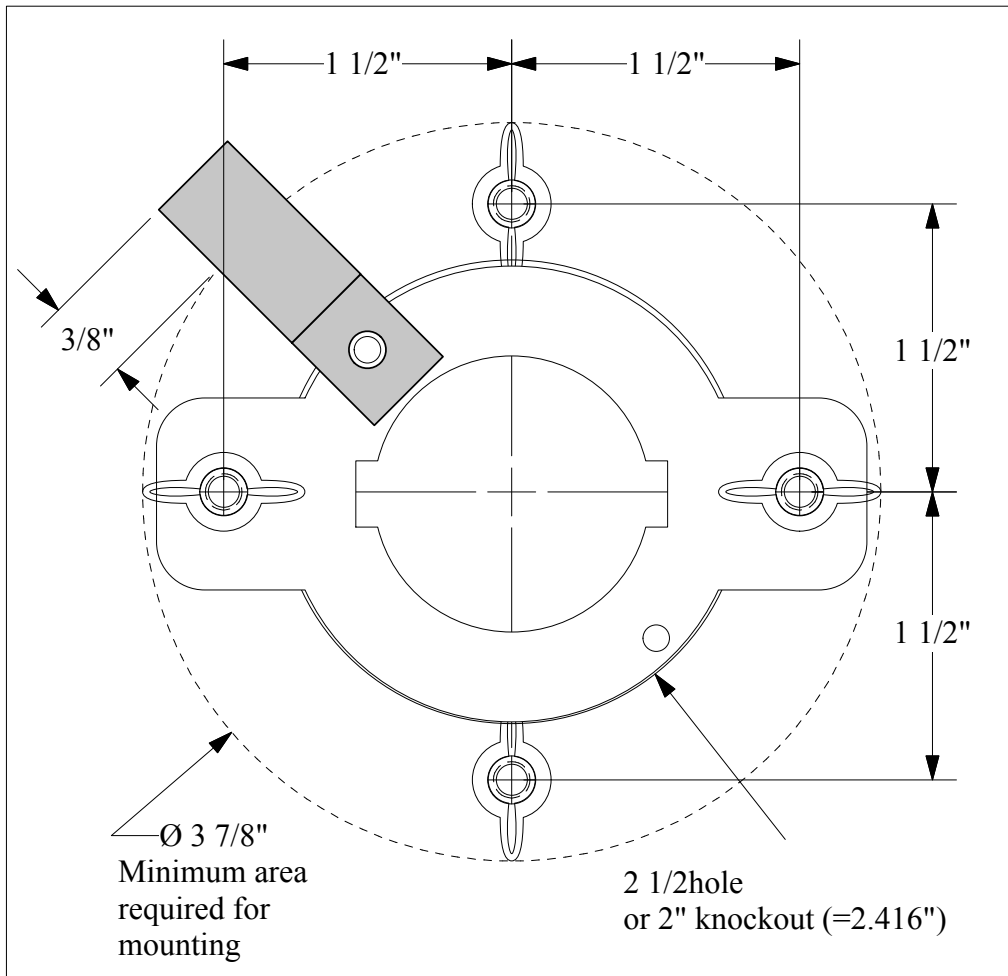

Mounting Templates

